

*AM1310nm field
laser transmitter (Relay station)*

TYPE:WT-8600III

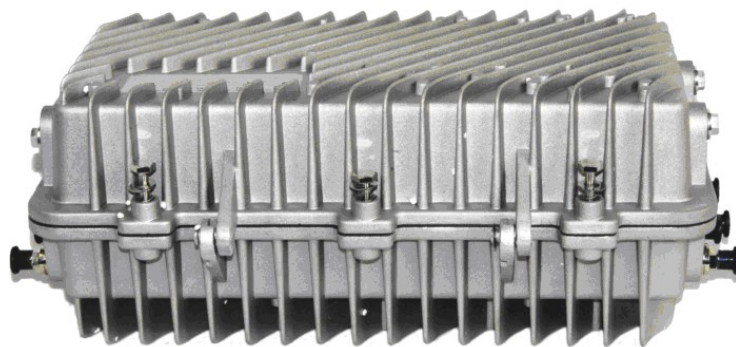

1. Product Summary

AM1310nm field laser transmitter (Relay station) is our featured product. With years accumulated HFC network engineering practice and equipment development experiences,

specifically developed for 1310nm field optical emission or optical relay transmission. The successful development of this product provides an economical and practical solution for the 1310nm field optical emission or optical relay transmission in CATV engineering practice.

2. Performance Characteristics

- Photoelectric conversion part adopts the latest imported brand-name optoelectronic integrated receiver module;
- Optical emission part adopts the latest imported brand high performance DFB laser; provide high quality signal transmission for the CATV network.
- Build-in RF driver amplifier and control circuit to ensure the low noise and intermodulation index; and can output two ways high quality RF signal to cover the local users.
- Perfect and reliable optical power output stabilizing circuit and built-in high-power electric heating cooler, enable the working ambient temperature difference up to $\pm 40^{\circ}\text{C}$, ensure the best performance of the machine and the long life steady operation of the laser.
- LCD status display, the main working parameters are clear at a glance.
- Compact and reasonable process structure, convenient installation and debugging, stable and reliable performance.
- The equipment can work steadily outdoor under bad environmental condition, because of large cast aluminium waterproof case, high reliability switching power supply and strict lightning protection system.

3. Technique Parameter

Item	Unit	Technical Parameter
Optical receiving part		
Input Optical Power	mw	0.3~1.6 (-5dBm~+2dBm)
Optical Connector Type		FC/APC or SC/APC
Optical Return Loss	dB	>45
Frequency Range	MHz	47~862
Flatness In Band	dB	±0.75
RF Output Level	dBμV	≥96 (when the input optical power is -2dBm)
Level Adjustment Range	dB	0~15
RF Characteristic Impedance	Ω	75
Return Loss	dB	≥ 16 (47~550) MHz; ≥ 14 (550~750/862MHz)
C/CTB	dB	≥ 65
C/CSO	dB	≥ 60
C/N	dB	≥ 51
AGC Control Range	dB	±8
MGC Control Range	dB	±8
Optical emission part		
Output Optical Power	mW	4, 6, 8, 10, 12, 14, 16 or specified by the user
Optical Link	dB	Defined according to optical power
Optical Modulation Mode		Direct optical intensity modulation
Operating Wavelength	nm	1310±20
Optical Connector Type		FC/APC or SC/APC,SC/UPC
Channel Number		84
C/N	dB	≥51
C/CTB	dB	≥65
C/CSO	dB	≥60
RF Input Level	dBμV	75~85 (Input level used as optical transmitter)
Input Laser Level	dBμV	93~98 (Laser input level used as relay station)
Flatness In Band	dB	±0.75

Generic characteristic		
Power Voltage	V	AC: (85~250V)/50 Hz or (35~75V) /50Hz
Consumption	W	<75
Operating Temperature	°C	-25 ~ +50
Storage Temperature	°C	-20 ~ +65
Relative Humidity	%	Max 95% No Condensation
Dimension	mm	537 (L) × 273 (W) × 220 (H)

Optical link carrier to noise ratio degradation table

Link loss (dB)	4	5	6	7	8	9	10	11	12	13	14	15	16
Optical power													
4mW	53.8	52.8	51.8	51.0	50.1	49.2	48.2						
6mW				53.0	52.0	51.0	50.1	49.1	48.1				
8 mW					52.8	51.9	51.0	50.1	49.1	48.2			
10 mW						52.9	51.9	51.0	50.1	49.1	48.2		
12 mW							52.7	51.8	50.8	49.9	49.0	48.0	
14 mW								52.4	51.5	50.5	49.5	48.6	47.8
16 mW									52.0	51.0	50.1	49.1	48.1

4. Block Diagram

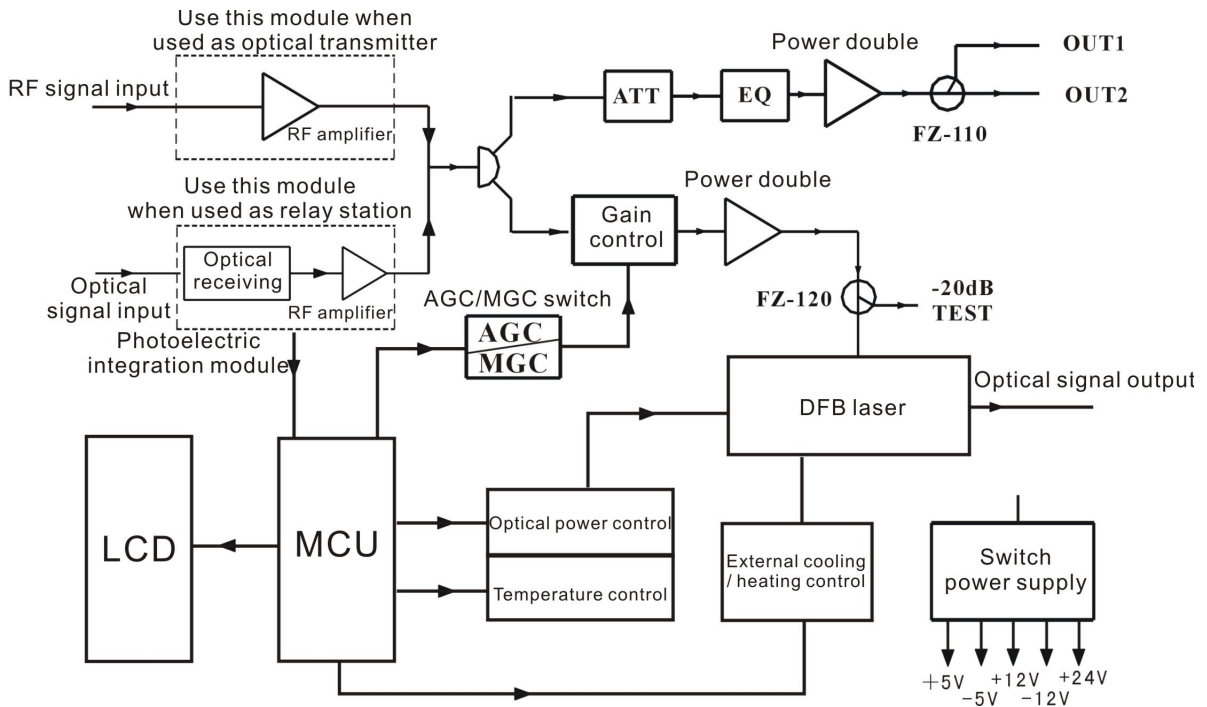

5. Structure specification

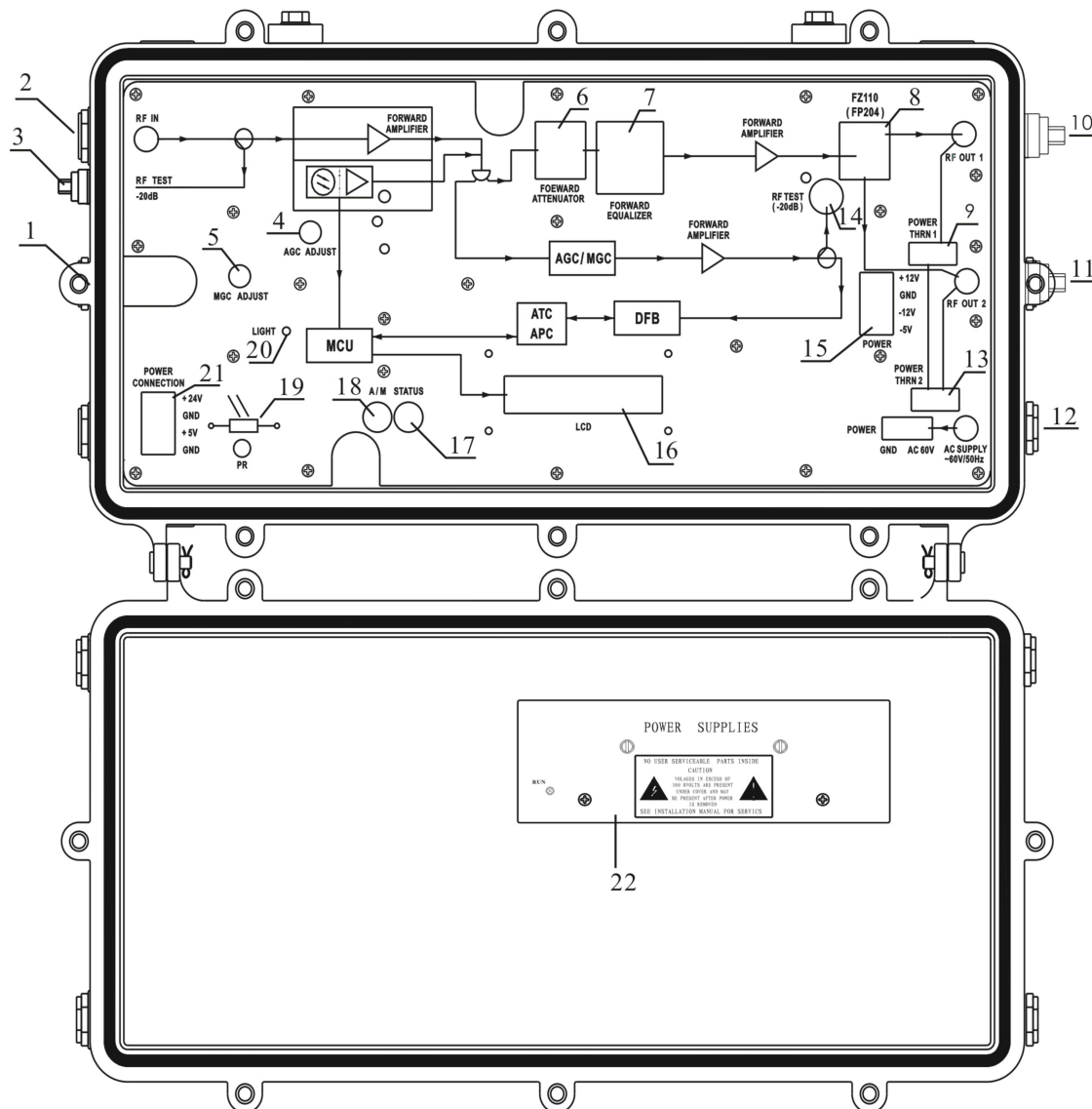

- | | |
|---|---|
| 1. Optical fiber input | 2. RF input (used as optical transmitter) |
| 3. -20dB input RF test port (used as optical transmitter) | 4. AGC control range adjustment |
| 5. Manual gain control potentiometer | 6. Forward fixed ATT inserter |
| 7. Forward fixed EQ inserter | 8. Forward tap and splitter |
| 9. Overcurrent inserter 1 | 10. RF Output 1 |
| 11. RF Output 2 | 12. AC 60 Power input |
| 13. Overcurrent inserter 2 | 14. -20dB Laser input RF test port |
| 17. Main Board power input 1 | 16. LCD display screen |
| 18. STATUS State select button | 18. A/M switch button |
| 19. Photosensitive device, automatically detects the lid open and close | |
| 20. Microprocessor operation instructions | |
| 21. Main Board power input 2 | 22. Switch power supply |

6. Status Display and Operating Instruction

1. Button function description
“STATUS” Status display select button;
“A/M” is AGC or MGC switch button.
2. Status display instructions

Power on, the default display status is input optical power (used as optical relay station):

- NO RePower (means input optical power $< -10\text{dBm}$).
- RePower :XX.XdBm (the actual input optical power, the range is $-10\sim 2\text{dBm}$).
- RePower Hight (means input optical power $> 2\text{dBm}$).

Press once “STATUS” button, change the current display status, followed by:

- 1) Laser output optical power: Power XX.X mW (the default display status when used as optical transmitter).
 - 2) Laser bias current: BIAS XX.X mA.
 - 3) Laser RF modulation level (Input RF):
Input RF: Low ! (means that the RF level is low).
OK (means that the RF level is normal).
HIGH (means that the RF level is high).
 - 4) RF gain control mode (RF Mode).
After entering this menu, switch the operating mode by A/M button, the screen will show corresponding display
RF Mode: AGC (System automatic gain control mode).
MGC (Manual gain control mode, control the RF gain by adjusting the MGC potentiometer).
 - 5) Laser operating temperature: Temp: XX.X °C
 - 6) -5V Voltage detection: -5V Read: -XX.X V
 - 7) +24V Voltage detection: +24V Read: +XX.X V
 - 8) Cooling/heating operating status display:
Cooling: XX.X A (show the cooling status operating current)
Heating: XX.X A (show the heating status operating current).
- Total 9 items content status display, press once “STATUS” button, change the current display status, followed by cycle.

7. Equipment debugging

- 1) AGC adjustment mode: RF working status switch to the AGC mode first, then connect the laser input RF test port (-20dB) to the field intensity indicator, adjust the AGC control potentiometer to make the display level of the field intensity indicator is in the range of 73dB-78dB.
- 2) MGC adjustment mode: RF working status switch to the MGC mode first, then connect the laser input RF test port (-20dB) to the field intensity indicator, adjust the MGC control potentiometer to make the display level of the field intensity indicator is in the range of 73dB-78dB.